



DESCRIPTION

The WM8141 is a 12-bit analogue front end/digitiser that processes and digitises the analogue output signals from CCDs or Contact Image Sensors (CIS). The device can be operated as either a three channel or a single channel device at pixel sample rates of up to 6MSPS. The device has both external and programmable internal black level reference options for CIS operation. The WM8141 runs off a single supply voltage of either 3.3V or 5V. Alternatively, the device can be operated from split 5V core and 3.3V digital interface supplies.

The WM8141 includes three analogue signal processing channels each of which contains reset level clamping, correlated double sampling and programmable offset and gain adjust facilities. Each of these channels is time multiplexed into a single high-speed 12-bit resolution ADC, which digitises the pixel image information. The digital data output is available to the user in either 12-bit parallel or 8/6/4-bit wide multiplexed formats.

The internal control registers are programmable via a convenient serial or parallel digital interface. The WM8141 typically consumes only 45mA and less than 10µA when in power down mode.

FEATURES

- 12-bit resolution ADC
- 6MSPS conversion rate at 5V supply
- 5V or 3.3V single supply or 5V/3.3V dual supply operation
- Single or 3 channel operation
- Correlated double sampling
- Programmable gain (8-bit resolution)
- Programmable offset adjust (8-bit resolution)
- 12-bit parallel or 8/6/4-bit wide multiplexed output bus
- Internally generated voltage references
- External or internal reference for CIS operation
- Low power – 225mW typical at 5V supply
- Interface and timing compatible with WM8143, WM8144 and WM8142 devices
- Drop in replacement for WM8143-12
- 32-pin TQFP package

APPLICATIONS

- Flatbed and sheetfeed scanners
- USB compatible scanners
- Multi-function peripherals
- CCD sensor interface
- Contact image sensor (CIS) interface

BLOCK DIAGRAM

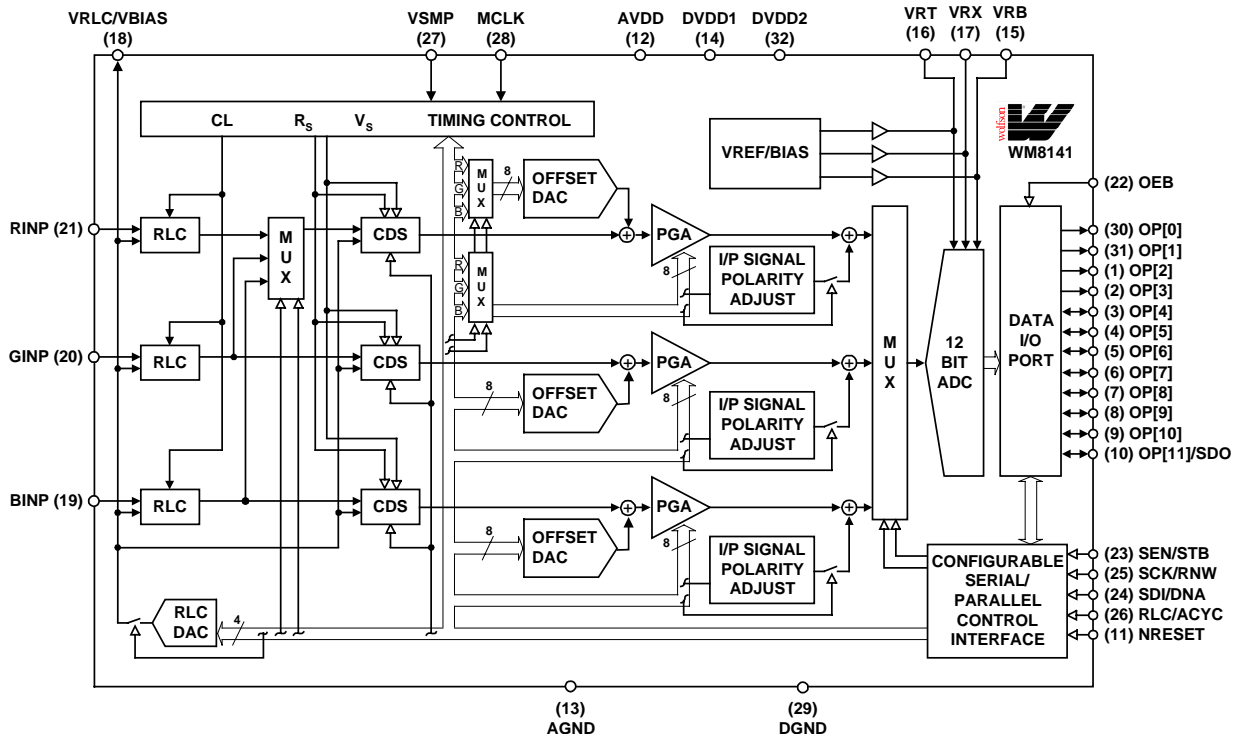

**PIN CONFIGURATION**

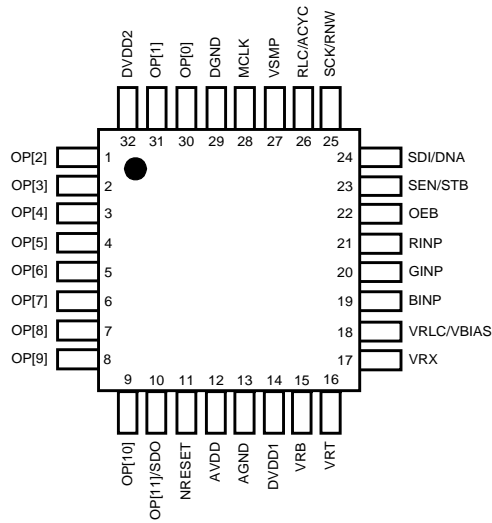

**ORDERING INFORMATION**

DEVICE	TEMP. RANGE	PACKAGE
WM8141CFT/V	0 to 70°C	32-pin TQFP

**PIN DESCRIPTION**

PIN	NAME	TYPE	DESCRIPTION
1	OP[2]	Digital output	Hi-Z digital 12-bit bi-directional bus. There are several modes: Hi-Z: when OEB = 1. 12-bit output: 12-bit data is output on OP[11:0]. 8-bit multiplexed output: data is output on OP[11:4] at 2 * ADC conversion rate. 6-bit multiplexed output: data is output on OP[11:6] at 2 * ADC conversion rate. 4-bit multiplexed output: data is output on OP[11:8] at 4 * ADC conversion rate. Input 8-bit: control data is input on OP[11:4] in parallel mode when SCK/RNW = 0, and SEN/STB = 0. Output 8-bit: register read back data is output in parallel on OP[11:4] when SCK/RNW = 1, and SEN/STB = 0, or in serial on pin SDO when SEN/STB = 1.
2	OP[3]	Digital output	
3	OP[4]	Digital IO	
4	OP[5]	Digital IO	
5	OP[6]	Digital IO	
6	OP[7]	Digital IO	
7	OP[8]	Digital IO	
8	OP[9]	Digital IO	
9	OP[10]	Digital IO	
10	OP[11]/SDO	Digital IO	
11	NRESET	Digital input	Reset input, active low. This signal forces a reset of all internal registers and selects whether the serial or parallel control bus is used (see SEN/STB).
12	AVDD	Supply	Analogue supply (3.3/5V) for CDS, PGA and OFFSET blocks. This must be operated at the same potential as DVDD1.
13	AGND	Supply	Analogue ground (0V).
14	DVDD1	Supply	Digital supply (3.3/5V) for logic and clock generator. This must be operated at the same potential as AVDD.
15	VRB	Analogue output	Lower reference voltage. This pin must be connected to AGND via a decoupling capacitor.
16	VRT	Analogue output	Upper reference voltage. This pin must be connected to AGND via a decoupling capacitor.
17	VRX	Analogue output	Input return bias voltage. This pin must be connected to AGND via a decoupling capacitor.
18	VRLC/VBIAS	Analogue IO	Selectable analogue output voltage for RLC or single-ended bias reference. This pin would typically be connected to AGND via a decoupling capacitor. VRLC can be externally driven if programmed Hi-Z.
19	BINP	Analogue input	Blue channel input video.
20	GINP	Analogue input	Green channel input video.
21	RINP	Analogue input	Red channel input video.
22	OEB	Digital input	Output Hi-Z control: all outputs disabled when OEB = 1.

PIN	NAME	TYPE	DESCRIPTION
23	SEN/STB	Digital input	Serial Interface: Enable pulse, active high. Parallel Interface: Strobe, active low.
			Latched on NRESET rising edge: If Low then device control is via serial interface, if High then device control is via parallel interface.
24	SDI/DNA	Digital input	Serial Interface: Serial input data signal. Parallel Interface: High = data, Low = address.
25	SCK/RNW	Digital input	Serial Interface: Serial clock signal. Parallel Interface: High = OP[11:4] is output bus, Low = OP[11:4] is input bus (Hi-Z)
26	RLC/ACYC	Digital input	Selects whether Reset Level Clamp is applied (active high). If RLC is required on every pixel then this pin can be tied high. ACYC, auto-cycles between RINP, GINP, BINP when in line by line mode.
27	VSMP	Digital input	Video sample synchronisation pulse.
28	MCLK	Digital input	Master clock. This clock is applied at N times the input pixel rate (N = 8, 6, 3 or 2 depending on the input sampling mode).
29	DGND	Supply	Digital ground (0V).
30	OP[0]	Digital output	Hi-Z digital 12-bit bi-directional bus, see description for pins OP[2] to OP[11]/SDO.
31	OP[1]	Digital output	
32	DVDD2	Supply	Digital supply (3.3/5V) for all digital pins.

## ABSOLUTE MAXIMUM RATINGS

Absolute Maximum Ratings are stress ratings only. Permanent damage to the device may be caused by continuously operating at or beyond these limits. Device functional operating limits and guaranteed performance specifications are given under Electrical Characteristics at the test conditions specified



ESD Sensitive Device. This device is manufactured on a CMOS process. It is therefore generically susceptible to damage from excessive static voltages. Proper ESD precautions must be taken during handling and storage of this device.

As per JEDEC specifications A112-A and A113-B, this product requires specific storage conditions prior to surface mount assembly. It has been classified as having a Moisture Sensitivity Level of 2 and as such will be supplied in vacuum-sealed moisture barrier bags.

CONDITION	MIN	MAX
Analogue supply voltage: AVDD	GND - 0.3V	GND + 7V
Digital supply voltages: DVDD1, DVDD2	GND - 0.3V	GND + 7V
Digital ground: DGND	GND - 0.3V	GND + 0.3V
Analogue ground: AGND	GND - 0.3V	GND + 0.3V
Digital inputs, digital outputs and digital pins	GND - 0.3V	DVDD2 + 0.3V
Analogue inputs (RINP, GINP, BINP)	GND - 0.3V	AVDD + 0.3V
Other pins	GND - 0.3V	AVDD + 0.3V
Operating temperature range: T <sub>A</sub>	0°C	+70°C
Storage temperature	-50°C	+150°C
Package body temperature (soldering, 10 seconds)		+240°C
Package body temperature (soldering, 2 minutes)		+183°C

- Notes:**
1. GND denotes the voltage of any ground pin.
  2. AGND and DGND pins are intended to be operated at the same potential. Differential voltages between these pins will degrade performance.
  3. AVDD and DVDD1 pins are intended to be operated at the same potential. Differential voltages between these pins will degrade performance.

**RECOMMENDED OPERATING CONDITIONS**

CONDITION	SYMBOL	MIN	TYP	MAX	UNITS
Operating temperature range	T <sub>A</sub>	0		70	°C
Digital supply voltages (5V operation)	DVDD1, DVDD2	4.75	5	5.25	V
Digital supply voltages (3.3V operation)	DVDD1, DVDD2	2.97	3.3	3.63	V
Analogue supply voltage (5V operation)	AVDD	4.75	5	5.25	V
Analogue supply voltage (3.3V operation)	AVDD	2.97	3.3	3.63	V

**POSSIBLE POWER SUPPLY COMBINATIONS**

COMBINATION	AVDD, DVDD1 (VOLTS)	DVDD2 (VOLTS)
1	5	5
2	5	3.3
3	3.3	3.3

**ELECTRICAL CHARACTERISTICS****ANALOGUE CHARACTERISTICS (5V OPERATION)****Test Conditions**

AVDD = DVDD1 = DVDD2 = 4.75 to 5.25V, AGND = DGND = 0V, T<sub>A</sub> = 0 to 70°C, MCLK = 12MHz unless otherwise stated.

PARAMETER	SYMBOL	TEST CONDITIONS	MIN	TYP	MAX	UNIT
<b>Overall System Specification Including CDS, PGA, OFFSET and ADC Functions. No Missing Codes Guaranteed.</b>						
Full-scale input voltage range (see Note 1)		Max Gain Min Gain		0.4 4.08		Vp-p Vp-p
Input signal limits (see Note 2)	V <sub>IN</sub>		0		AVDD	V
Full-scale transition error		Gain = 0dB; PGA[7:0] = 4B(hex)		20		mV
Zero-scale transition error		Gain = 0dB; PGA[7:0] = 4B(hex)		20		mV
Differential non-linearity	DNL			0.5	1	LSB
Integral non-linearity	INL			2		LSB
Channel to channel gain matching				1		%
<b>References</b>						
Upper reference voltage	VRT		2.70	2.85	3.00	V
Lower reference voltage	VRB		1.25	1.35	1.45	V
Input return bias voltage	VRX		0.60	0.65	0.70	V
Diff. reference voltage (VRT-VRB)	V <sub>RTB</sub>		1.4	1.5	1.6	V
Output resistance VRT, VRB, VRX				1		Ω

**Test Conditions**AVDD = DVDD1 = DVDD2 = 4.75 to 5.25V, AGND = DGND = 0V, T<sub>A</sub> = 0 to 70°C, MCLK = 12MHz unless otherwise stated.

PARAMETER	SYMBOL	TEST CONDITIONS	MIN	TYP	MAX	UNIT
<b>VRLC/Reset-Level Clamp (RLC)</b>						
RLC switching impedance				50		Ω
VRLC short-circuit current				5		mA
VRLC output resistance				2		Ω
VRLC Hi-Z leakage current					1	μA
RLCDAC resolution				4		bits
RLCDAC step size, RLCDAC = 0	V <sub>RLCSTEP</sub>			0.24		V/step
RLCDAC step size, RLCDAC = 1	V <sub>RLCSTEP</sub>			0.16		V/step
RLCDAC output voltage at code 0(hex), RLCDACRNG = 0	V <sub>RLCBOT</sub>			0.4		V
RLCDAC output voltage at code 0(hex), RLCDACRNG = 1	V <sub>RLCBOT</sub>			0.25		V
RLCDAC output voltage at code F(hex) RLCDACRNG, = 0	V <sub>RLCTOP</sub>			4.2		V
RLCDAC output voltage at code F(hex), RLCDACRNG = 1	V <sub>RLCTOP</sub>			2.85		V
<b>Offset DAC, Monotonicity Guaranteed</b>						
Resolution				8		bits
Differential non-linearity	DNL			0.1	0.5	LSB
Integral non-linearity	INL			0.25	1	LSB
Step size				2.04		mV/step
Output voltage		Code 00(hex) Code FF(hex)		-260 +260		mV mV
<b>Programmable Gain Amplifier</b>						
Resolution				8		bits
Gain				$\frac{208}{283 - \text{PGA}[7:0]}$		V/V
Max gain, each channel	G <sub>MAX</sub>			7.4		V/V
Min gain, each channel	G <sub>MIN</sub>			0.74		V/V
Gain error, each channel				1	5	%
<b>Supply Currents</b>						
Total supply current – active				45	65	mA
Total analogue supply current – active	I <sub>AVDD</sub>			42		mA
Digital logic supply current, DVDD1 – active				2		mA
Digital I/O supply current, DVDD2 – active				1		mA
Supply current – full power down mode				10		μA

- Notes:**
1. **Full-scale input voltage** denotes the maximum amplitude of the input signal at the specified gain.
  2. **Input signal limits** are the limits within which the full-scale input voltage signal must lie.

**ANALOGUE CHARACTERISTICS (3.3V OPERATION)****Test Conditions**

AVDD = DVDD1 = DVDD2 = 2.97V to 3.63V, AGND = DGND = 0V, T<sub>A</sub> = 0 to 70°C, MCLK = 8MHz unless otherwise stated.

PARAMETER	SYMBOL	TEST CONDITIONS	MIN	TYP	MAX	UNIT
<b>Overall System Specification Including CDS, PGA, OFFSET and ADC Functions.</b>						
Full-scale input voltage range (see Note 1)		Max Gain Min Gain		0.2 2.04		V <sub>p-p</sub> V <sub>p-p</sub>
Input signal limits (see Note 2)	V <sub>IN</sub>		0		AVDD	V
Full-scale transition error		Gain = 0dB; PGA[7:0] = 4B(hex)		20		mV
Zero-scale transition error		Gain = 0dB; PGA[7:0] = 4B(hex)		20		mV
Differential non-linearity	DNL			0.5		LSB
Integral non-linearity	INL			2		LSB
Channel to channel gain matching				1		%
<b>References</b>						
Upper reference voltage	VRT		1.625	1.725	1.825	V
Lower reference voltage	VRB		0.900	0.975	1.050	V
Input return bias voltage	VRX		0.60	0.65	0.70	V
Diff. reference voltage (VRT-VRB)	V <sub>RTB</sub>		0.65	0.75	0.85	V
Output resistance VRT, VRB, VRX				1		Ω
<b>VRLC/Reset-Level Clamp (RLC)</b>						
RLC switching impedance				140		Ω
VRLC short-circuit current				5		mA
VRLC output resistance				2		Ω
VRLC Hi-Z leakage current				<0.1		μA
RLCDAC resolution				4		bits
RLCDAC step size, RLCDAC = 0	V <sub>RLCSTEP</sub>			0.16		V/step
RLCDAC step size, RLCDAC = 1	V <sub>RLCSTEP</sub>			0.09		V/step
RLCDAC output voltage at code 0(hex), RLCDACRNG = 0	V <sub>RLCBOT</sub>			0.25		V
RLCDAC output voltage at code 0(hex), RLCDACRNG = 1	V <sub>RLCBOT</sub>			0.2		V
RLCDAC output voltage at code F(hex), RLCDACRNG = 0	V <sub>RLCTOP</sub>			2.75		V
RLCDAC output voltage at code F(hex), RLCDACRNG = 1	V <sub>RLCTOP</sub>			1.7		V
<b>Offset DAC</b>						
Resolution				8		bits
Differential non-linearity	DNL			0.1		LSB
Integral non-linearity	INL			0.25		LSB
Step size				1.02		mV/step
Output voltage		Code 00(hex) Code FF(hex)		-130 +130		mV mV
<b>Programmable Gain Amplifier</b>						
Resolution				8		bits
Gain				$\frac{208}{283 - \text{PGA}[7:0]}$		V/V
Max gain, each channel	G <sub>MAX</sub>			7.4		V/V
Min gain, each channel	G <sub>MIN</sub>			0.74		V/V
Gain error, each channel				1		%

- Notes:** 1. **Full-scale input voltage** denotes the maximum amplitude of the input signal at the specified gain.  
2. **Input signal limits** are the limits within which the full-scale input voltage signal must lie.

**Test Conditions**AVDD = DVDD1 = DVDD2 = 2.97V to 3.63V, AGND = DGND = 0V, T<sub>A</sub> = 0 to 70°C, MCLK = 8MHz unless otherwise stated.

PARAMETER	SYMBOL	TEST CONDITIONS	MIN	TYP	MAX	UNIT
<b>Supply Currents</b>						
Total supply current – active				43		mA
Total analogue supply current – active	I <sub>AVDD</sub>			40		mA
Digital logic supply current, DVDD1 – active				2		mA
Digital I/O supply current, DVDD2 – active				1		mA
Supply current – full power down mode				10		µA

**DIGITAL CHARACTERISTICS****Test Conditions**AVDD = DVDD1 = DVDD2 = 2.97V to 5.25V, AGND = DGND = 0V, T<sub>A</sub> = 0 to 70°C, MCLK = 12MHz unless otherwise stated.

PARAMETER	SYMBOL	TEST CONDITIONS	MIN	TYP	MAX	UNIT
<b>DIGITAL SPECIFICATIONS</b>						
<b>Digital Inputs</b>						
High level input voltage	V <sub>IH</sub>		0.8 * DVDD2			V
Low level input voltage	V <sub>IL</sub>				0.2 * DVDD2	V
High level input current	I <sub>IH</sub>				1	µA
Low level input current	I <sub>IL</sub>				1	µA
Input capacitance	C <sub>I</sub>			5		pF
<b>Digital Outputs</b>						
High level output voltage	V <sub>OH</sub>	I <sub>OH</sub> = 1mA	DVDD2 - 0.5			V
Low level output voltage	V <sub>OL</sub>	I <sub>OL</sub> = 1mA			0.5	V
High impedance output current	I <sub>OZ</sub>				1	µA
<b>Digital IO Pins</b>						
Applied high level input voltage	V <sub>IH</sub>		0.8 * DVDD2			V
Applied low level input voltage	V <sub>IL</sub>				0.2 * DVDD2	V
High level output voltage	V <sub>OH</sub>	I <sub>OH</sub> = 1mA	DVDD2 - 0.5			V
Low level output voltage	V <sub>OL</sub>	I <sub>OL</sub> = 1mA			0.5	V
Low level input current	I <sub>IL</sub>				1	µA
High level input current	I <sub>IH</sub>				1	µA
Input capacitance	C <sub>I</sub>			5		pF
High impedance output current	I <sub>OZ</sub>				1	µA

**INPUT VIDEO SAMPLING**

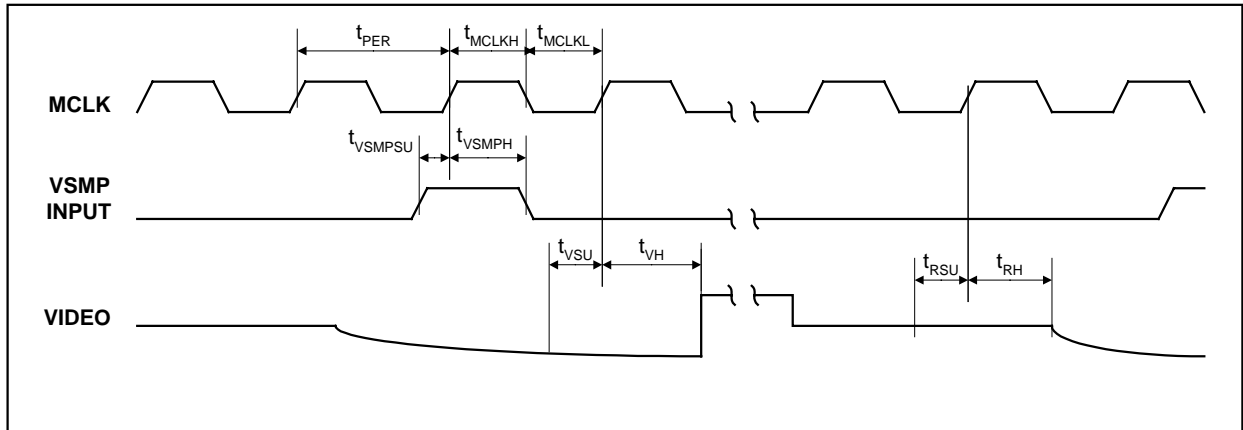

**Figure 1 Input Video Timing**

**Test Conditions**

AVDD = DVDD1 = DVDD2 = 4.75 to 5.25V, AGND = DGND = 0V,  $T_A = 0$  to  $70^\circ\text{C}$ , MCLK = 12MHz unless otherwise stated

PARAMETER	SYMBOL	TEST CONDITIONS	MIN	TYP	MAX	UNITS
MCLK period	$t_{PER}$		83.3			ns
MCLK high period	$t_{MCLKH}$		37.5			ns
MCLK low period	$t_{MCLKL}$		37.5			ns
VSMP set-up time	$t_{VSMPHU}$		10			ns
VSMP hold time	$t_{VSMPHL}$		10			ns
Video level set-up time	$t_{VSU}$		10			ns
Video level hold time	$t_{VH}$		15			ns
Reset level set-up time	$t_{RSU}$		10			ns
Reset level hold time	$t_{RH}$		15			ns

- Notes:** 1.  $t_{VSU}$  and  $t_{RSU}$  denote the set-up time required after the input video signal has settled.  
 2. Parameters are measured at 50% of the rising/falling edge.

**OUTPUT DATA TIMING**

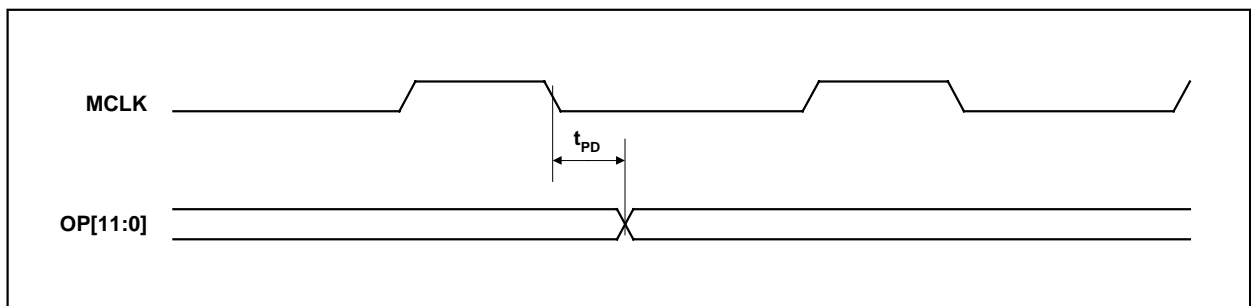

**Figure 2 Output Data Timing**



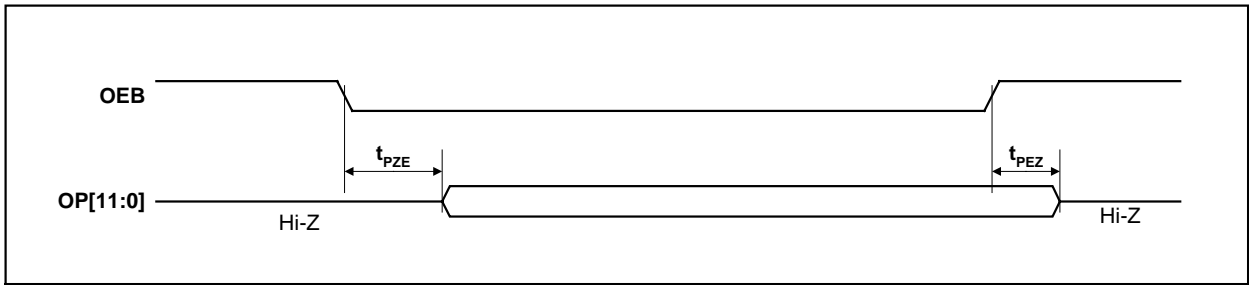

Figure 3 Output Data Enable Timing

**Test Conditions**

AVDD = DVDD1 = DVDD2 = 4.75 to 5.25V, AGND = DGND = 0V, T<sub>A</sub> = 0 to 70°C, MCLK = 12MHz unless otherwise stated

PARAMETER	SYMBOL	TEST CONDITIONS	MIN	TYP	MAX	UNITS
Output propagation delay	t <sub>PD</sub>	I <sub>OH</sub> = 1mA, I <sub>OL</sub> = 1mA			75	ns
Output enable time	t <sub>PZE</sub>				50	ns
Output disable time	t <sub>PEZ</sub>				25	ns

**SERIAL INTERFACE**

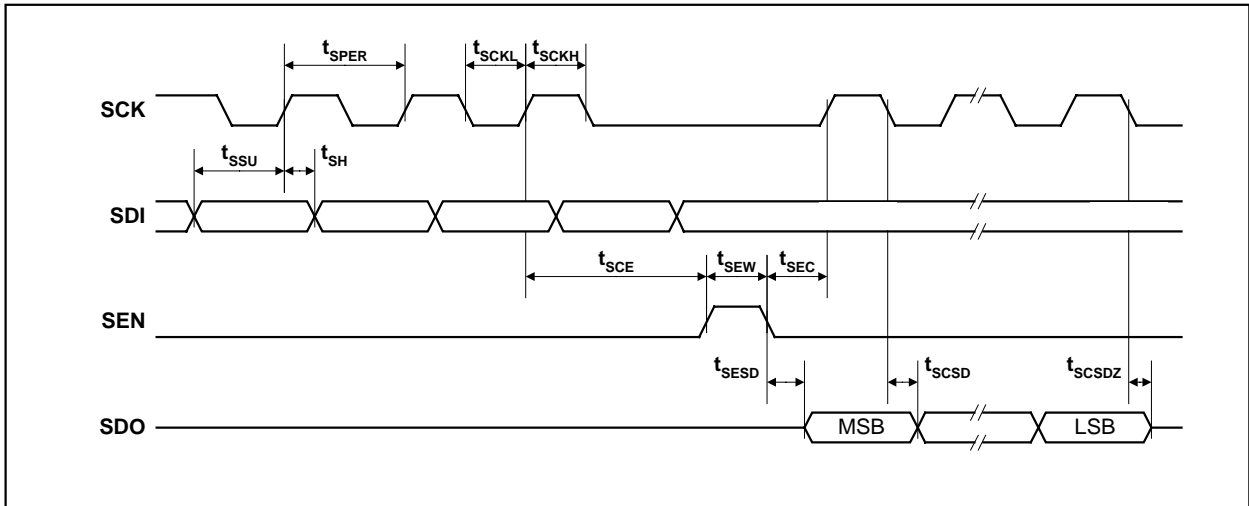

Figure 4 Serial Interface Timing

**Test Conditions**

AVDD = DVDD1 = DVDD2 = 4.75 to 5.25V, AGND = DGND = 0V, T<sub>A</sub> = 0 to 70°C, MCLK = 12MHz unless otherwise stated

PARAMETER	SYMBOL	TEST CONDITIONS	MIN	TYP	MAX	UNITS
SCK period	t <sub>SPER</sub>		83.3			ns
SCK high	t <sub>SCKH</sub>		37.5			ns
SCK low	t <sub>SCKL</sub>		37.5			ns
SDI set-up time	t <sub>SSU</sub>		10			ns
SDI hold time	t <sub>SH</sub>		10			ns
SCK to SEN set-up time	t <sub>SCE</sub>		20			ns
SEN to SCK set-up time	t <sub>SEC</sub>		20			ns
SEN pulse width	t <sub>SEW</sub>		50			ns
SEN low to SDO out	t <sub>SESD</sub>				35	ns
SCK low to SDO out	t <sub>SCD</sub>				35	ns
SCK low to SDO high impedance	t <sub>SCDZ</sub>				25	ns

**Note:** Parameters are measured at 50% of the rising/falling edge.

PARALLEL INTERFACE

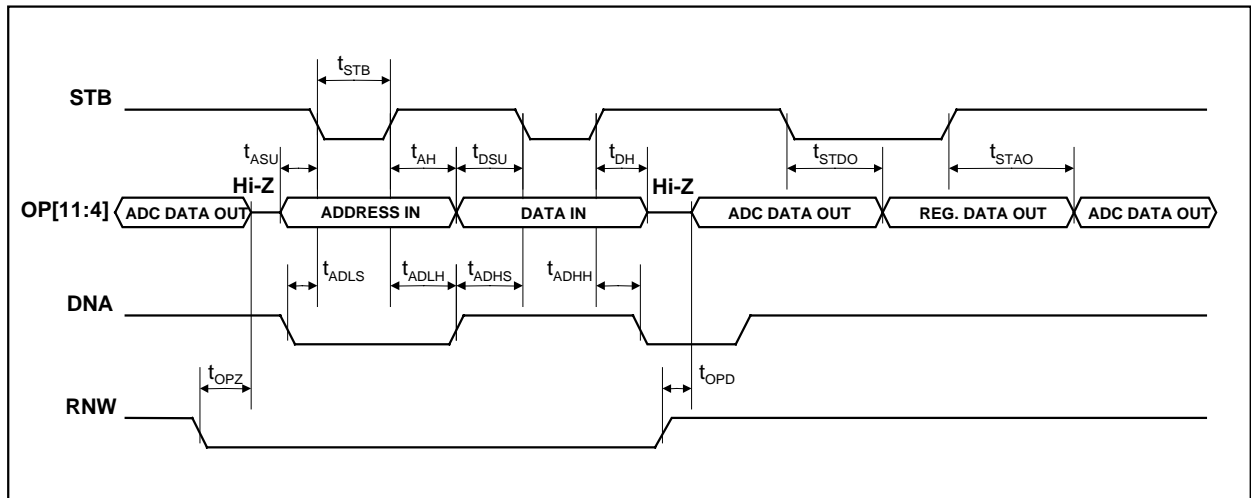

Figure 5 Parallel Interface Diagram

Test Conditions

AVDD = DVDD1 = DVDD2 = 4.75 to 5.25V, AGND = DGND = 0V, T<sub>A</sub> = 0 to 70°C, MCLK = 12MHz unless otherwise stated

PARAMETER	SYMBOL	TEST CONDITIONS	MIN	TYP	MAX	UNITS
RNW low to OP[11:4] tri-state.	t <sub>OPZ</sub>				20	ns
Address set-up time to STB low	t <sub>ASU</sub>		0			ns
DNA low set-up time to STB low	t <sub>ADLS</sub>		10			ns
Strobe low time	t <sub>STB</sub>		50			ns
Address hold time from STB high	t <sub>AH</sub>		10			ns
DNA low hold time from STB high	t <sub>ADLH</sub>		10			ns
Data set-up time to STB low	t <sub>DSU</sub>		0			ns
DNA high set-up time to STB low	t <sub>ADHS</sub>		10			ns
Data hold time from STB high	t <sub>DH</sub>		10			ns
Data high hold time from STB high	t <sub>ADHH</sub>		10			ns
RNW high to OP[11:4] output	t <sub>OPD</sub>				35	ns
Data output propagation delay from STB low	t <sub>STDO</sub>				35	ns
ADC data out propagation delay from STB high	t <sub>STAO</sub>				35	ns

Note: Parameters are measured at 50% of the rising/falling edge.

## DEVICE DESCRIPTION

### INTRODUCTION

A block diagram of the device showing the signal path is presented on Page 1.

The WM8141 samples up to three inputs (RINP, GINP and BINP) simultaneously. The device then processes the sampled video signal with respect to the video reset level or an internally/externally generated reference level using either one or three processing channels.

Each processing channel consists of an Input Sampling block with optional Reset Level Clamping (RLC) and Correlated Double Sampling (CDS), an 8-bit programmable offset DAC and an 8-bit Programmable Gain Amplifier (PGA).

The ADC then converts each resulting analogue signal to a 12-bit digital word. The digital output from the ADC is presented on a 12-bit wide bi-directional bus, with optional 8+4-bit, 6+6-bit or 4+4+4-bit multiplexed formats.

On-chip control registers determine the configuration of the device, including the offsets and gains applied to each channel. These registers are programmable via serial or parallel interfaces.

### INPUT SAMPLING

The WM8141 can sample and process one to three inputs through one or three processing channels as follows:

**Colour Pixel-by-Pixel:** The three inputs (RINP, GINP and BINP) are simultaneously sampled for each pixel and a separate channel processes each input. The signals are then multiplexed into the ADC, which converts all three inputs within the pixel period.

**Monochrome:** A single chosen input (RINP, GINP, or BINP) is sampled, processed by the corresponding channel, and converted by the ADC. The choice of input and channel can be changed via the control interface, e.g. on a line-by-line basis if required.

**Colour Line-by-Line:** A single chosen input (RINP, GINP, or BINP) is sampled and multiplexed into the red channel for processing before being converted by the ADC. The input selected can be switched in turn (RINP → GINP → BINP → RINP...) together with the PGA and Offset DAC control registers by pulsing the RLC/ACYC pin. This is known as auto-cycling. Alternatively, other sampling sequences can be generated via the control registers. This mode causes the blue and green channels to be powered down. Refer to the Line-by-Line Operation section for more details.

### RESET LEVEL CLAMPING (RLC)

To ensure that the signal applied to the WM8141 lies within its input range (0V to AVDD) the CCD output signal is usually level shifted by coupling through a capacitor,  $C_{IN}$ . The RLC circuit clamps the WM8141 side of this capacitor to a suitable voltage during the CCD reset level.

A typical input configuration is shown in Figure 5. A clamp pulse, CL, is generated from MCLK and VSMP by the Timing Control Block. When CL is active the voltage on the WM8141 side of  $C_{IN}$ , at RINP, is forced to the VRLC/VBIAS voltage ( $V_{VRLC}$ ) by switch 1. When the CL pulse turns off, the voltage at RINP initially remains at  $V_{VRLC}$  but any subsequent variation in sensor voltage (from reset to video level) will couple through  $C_{IN}$  to RINP.

RLC is compatible with both CDS and non-CDS operating modes, as selected by switch 2. Refer to the CDS/non-CDS Processing section.

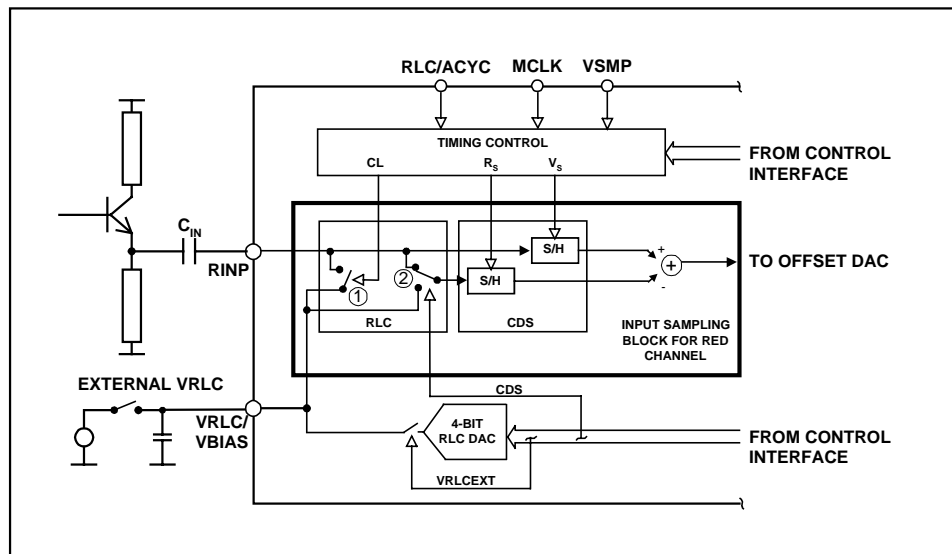
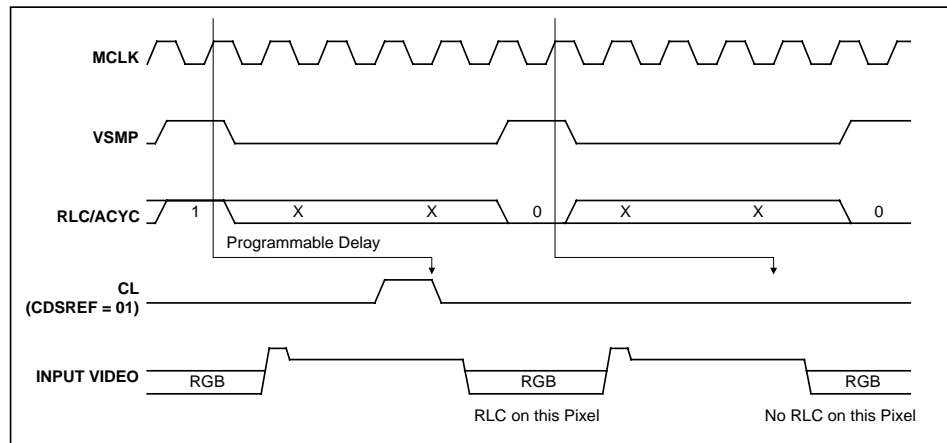

**Figure 6 Reset Level Clamping and CDS Circuitry**

If auto-cycling is not required, RLC can be selected by pin RLC/ACYC. Figure 6 illustrates control of RLC for a typical CCD waveform, with CL applied during the reset period.

The input signal applied to the RLC pin is sampled on the positive edge of MCLK that occurs during each VSMP pulse. The sampled level, high (or low) controls the presence (or absence) of the internal CL pulse on the next reset level. The position of CL can be adjusted by using control bits CDSREF[1:0] (Figure 7).

If auto-cycling is required, pin RLC/ACYC is no longer available for this function and control bit RLCINT determines whether clamping is applied.



**Figure 7 Relationship of RLC Pin, MCLK and VSMP to Internal Clamp Pulse, CL**

The VRLC/VBIAS pin can be driven internally by a 4-bit DAC (RLCDAC) by writing to control bits RLCV[3:0]. The RLCDAC range and step size may be increased by writing to control bit RLCDACRNG. Alternatively, the VRLC/VBIAS pin can be driven externally by writing to control bit VRLCEXT to disable the RLCDAC and then applying a d.c. voltage to the pin.

**CDS/NON-CDS PROCESSING**

For CCD type input signals, the signal may be processed using CDS, which will remove pixel-by-pixel common mode noise. For CDS operation, the video level is processed with respect to the video reset level, regardless of whether RLC has been performed. To sample using CDS, control bit CDS must be set to 1 (default), this controls switch 2 (Figure 6) and causes the signal reference to come from the video reset level. The time at which the reset level is sampled, by clock  $R_s/CL$ , is adjustable by programming control bits CDSREF[1:0], as shown in Figure 8.

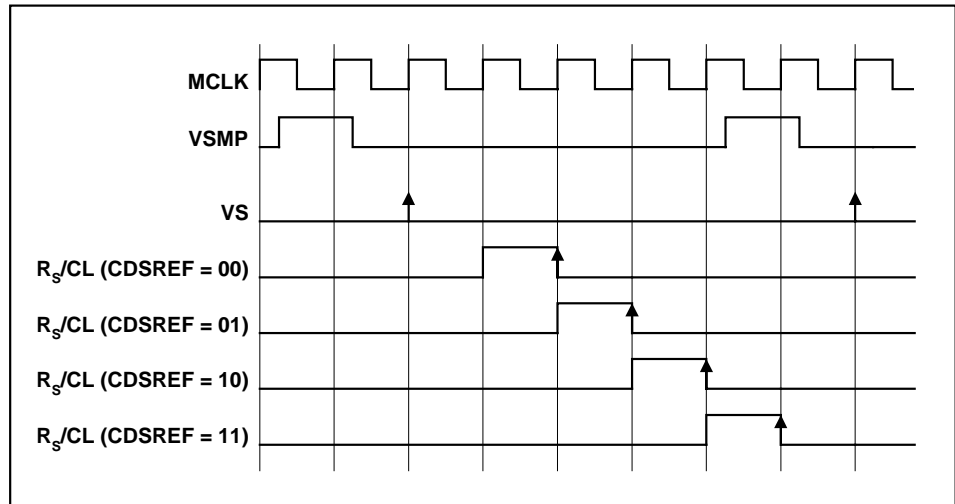

Figure 8 Reset Sample and Clamp Timing

For CIS type sensor signals, non-CDS processing is used. In this case, the video level is processed with respect to the voltage on pin VRLC/VBIAS, generated internally or externally as described above. The VRLC/VBIAS pin is sampled by R<sub>s</sub> at the same time as V<sub>s</sub> samples the video level in this mode.

### OFFSET ADJUST AND PROGRAMMABLE GAIN

The output from the CDS block is a differential signal, which is added to the output of an 8-bit Offset DAC to compensate for offsets and then amplified by an 8-bit PGA. The gain and offset for each channel are independently programmable by writing to control bits DAC[7:0] and PGA[7:0].

In colour line-by-line mode the gain and offset coefficients for each colour can be multiplexed in order (Red → Green → Blue → Red...) by pulsing the ACYC/RLC pin, or controlled via the FME, ACYCNRLC and INTM[1:0] bits. Refer to the Line-by-line Operation section for more details.

### ADC INPUT BLACK LEVEL ADJUST

The output from the PGA must be offset to match the full-scale range of the ADC. For negative-going input signals, a black level (zero differential) output from the PGA should be offset to the top of the ADC range. For positive going input signal the black level should be offset to the bottom of the ADC range. This is achieved by writing to control bits PGAFS[1:0].

### OVERALL SIGNAL FLOW SUMMARY

Figure 9 represents the processing of the video signal through the WM8141.

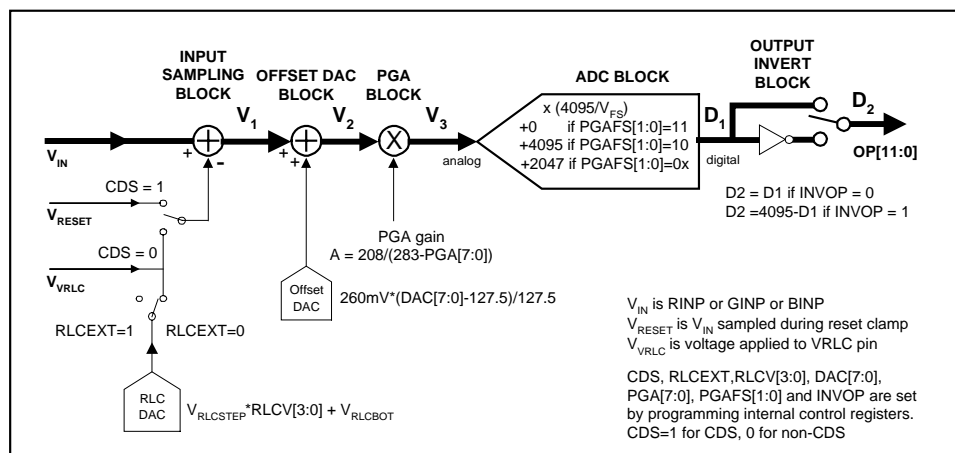

Figure 9 Overall Signal Flow

The **INPUT SAMPLING BLOCK** produces an effective input voltage  $V_1$ . For CDS, this is the difference between the input video level  $V_{IN}$  and the input reset level  $V_{RESET}$ . For non-CDS this is the difference between the input video level  $V_{IN}$  and the voltage on the VRLC/VBIAS pin,  $V_{VRLC}$ , optionally set via the RLC DAC.

The **OFFSET DAC BLOCK** then adds the amount of fine offset adjustment required to move the black level of the input signal towards 0V, producing  $V_2$ .

The **PGA BLOCK** then amplifies the white level of the input signal to maximise the ADC range, outputting voltage  $V_3$ .

The **ADC BLOCK** then converts the analogue signal,  $V_3$ , to a 12-bit unsigned digital output,  $D_1$ .

The digital output is then inverted, if required, through the **OUTPUT INVERT BLOCK** to produce  $D_2$ .

**CALCULATING OUTPUT FOR ANY GIVEN INPUT**

The following equations describe the processing of the video and reset level signals through the WM8141.

**INPUT SAMPLING BLOCK: INPUT SAMPLING AND REFERENCING**

If CDS = 1, (i.e. CDS operation) the previously sampled reset level,  $V_{RESET}$ , is subtracted from the input video.

$$V_1 = V_{IN} - V_{RESET} \dots\dots\dots \text{Eqn. 1}$$

If CDS = 0, (non-CDS operation) the simultaneously sampled voltage on pin VRLC is subtracted instead.

$$V_1 = V_{IN} - V_{VRLC} \dots\dots\dots \text{Eqn. 2}$$

If RLCEXT = 1,  $V_{VRLC}$  is an externally applied voltage on pin VRLC/VBIAS.

If RLCEXT = 0,  $V_{VRLC}$  is the output from the internal RLC DAC.

$$V_{VRLC} = (V_{RLCSTEP} * RLCV[3:0]) + V_{RLCBOT} \dots\dots\dots \text{Eqn. 3}$$

$V_{RLCSTEP}$  is the step size of the RLC DAC and  $V_{RLCBOT}$  is the minimum output of the RLC DAC.

**OFFSET DAC BLOCK: OFFSET (BLACK-LEVEL) ADJUST**

The resultant signal  $V_1$  is added to the Offset DAC output.

$$V_2 = V_1 + \{260\text{mV} * (\text{DAC}[7:0] - 127.5)\} / 27.5 \dots\dots\dots \text{Eqn. 4}$$

**PGA NODE: GAIN ADJUST**

The signal is then multiplied by the PGA gain,

$$V_3 = V_2 * 208 / (283 - \text{PGA}[7:0]) \dots\dots\dots \text{Eqn. 5}$$

**ADC BLOCK: ANALOGUE-DIGITAL CONVERSION**

The analogue signal is then converted to a 12-bit unsigned number, with input range configured by PGAFS[1:0].

$$D_1[11:0] = \text{INT}\{ (V_3 / V_{FS}) * 4095\} + 2047 \quad \text{PGAFS}[1:0] = 00 \text{ or } 01 \dots\dots \text{Eqn. 6}$$

$$D_1[11:0] = \text{INT}\{ (V_3 / V_{FS}) * 4095\} \quad \text{PGAFS}[1:0] = 11 \dots\dots\dots \text{Eqn. 7}$$

$$D_1[11:0] = \text{INT}\{ (V_3 / V_{FS}) * 4095\} + 4095 \quad \text{PGAFS}[1:0] = 10 \dots\dots\dots \text{Eqn. 8}$$

where the ADC full-scale range,  $V_{FS} = 3\text{V}$  at  $\text{AVDD} = 5\text{V}$  and  $V_{FS} = 1.5\text{V}$  at  $\text{AVDD} = 3.3\text{V}$

**OUTPUT INVERT BLOCK: POLARITY ADJUST**

The polarity of the digital output may be inverted by control bit INVOP.

$$D_2[11:0] = D_1[11:0] \quad (\text{INVOP} = 0) \dots\dots\dots \text{Eqn. 9}$$

$$D_2[11:0] = 4095 - D_1[11:0] \quad (\text{INVOP} = 1) \dots\dots\dots \text{Eqn. 10}$$

## OUTPUT FORMATS

The digital data output from the ADC is available to the user in either 12-bit parallel or 8/6/4-bit wide multiplexed formats by setting control bits MUXOP[1:0]. Latency of valid output data with respect to VSMP is programmable by writing to control bits DEL[1:0]. The latency for each mode is shown in the Mode Timing Diagrams section.

Figure 10 shows the output data formats for Modes 1 – 2 and 4 – 6. Figure 11 shows the output data formats for Mode 3. Table 1 summarises the output data obtained for each format.

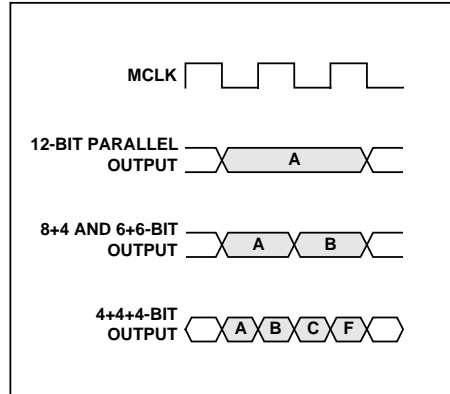

Figure 10 Output Data Formats (Modes 1 – 2, 4 – 6)

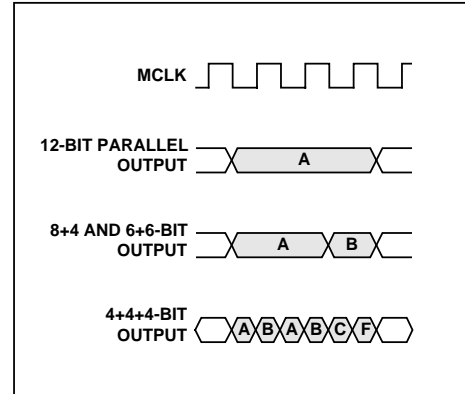

Figure 11 Output Data Formats (Mode 3)

OUTPUT FORMAT	MUXOP[1:0]	OUTPUT PINS	OUTPUT
12-bit parallel	00	OP[11:0]	A = d11, d10, d9, d8, d7, d6, d5, d4, d3, d2, d1, d0
8+4-bit multiplexed	01	OP[11:4]	A = d11, d10, d9, d8, d7, d6, d5, d4 B = d3, d2, d1, d0, PNS, CC[1], CC[0], OVRNG
6+6-bit multiplexed	10	OP[11:4]	A = d11, d10, d9, d8, d7, d6, CC[1], CC[0] B = d5, d4, d3, d2, d1, d0, PNS, OVRNG
4+4+4-bit multiplexed (nibble)	11	OP[11:8]	A = d11, d10, d9, d8 B = d7, d6, d5, d4 C = d3, d2, d1, d0 F = PNS, CC[1], CC[0], OVRNG

Table 1 Details of Output Data Shown in Figures 9 and 10

### FLAGS

The following flags are output during multiplexed modes:

PNS indicates whether the control interface is operating in parallel or serial, 1 = parallel, 0 = serial.

CC[1] and CC[0] indicate from which input the current output was sampled:

INPUT	CC[1]	CC[0]
RINP	0	0
GINP	0	1
BINP	1	0

Table 2 Input Sampled Flags CC[1:0]

OVRNG indicates that the current output data was produced by an input signal that exceeded the input range limit of the device. 1 = out of range, 0 = within range.

**CONTROL INTERFACE**

The internal control registers are programmable via the serial or parallel digital control interface. The register contents can also be read back via the parallel interface on OP[11:4], or via the serial interface on pin OP[11]/SDO.

**SERIAL INTERFACE: REGISTER WRITE**

Figure 12 shows register writing in serial mode. Three pins, SCK, SDI and SEN are used. A six-bit address (a5, 0, a3, a2, a1, a0) is clocked in through SDI, MSB first, followed by an eight-bit data word (b7, b6, b5, b4, b3, b2, b1, b0), also MSB first. Each bit is latched on the rising edge of SCK. When the data has been shifted into the device, a pulse is applied to SEN to transfer the data to the appropriate internal register. Note all valid registers have address bit a4 equal to 0 in write mode.

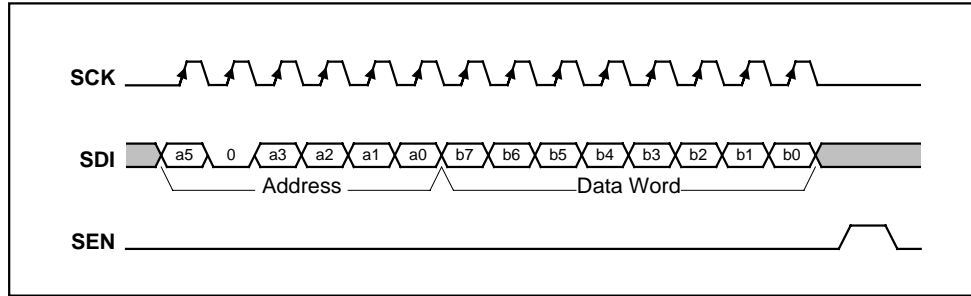

Figure 12 Serial Interface Register Write

**SERIAL INTERFACE: REGISTER READ-BACK**

Figure 13 shows register read-back in serial mode. Read-back is initiated by writing to the serial bus as described above but with address bit a4 set to 1, followed by an 8-bit dummy data word. Writing address (a5, 1, a3, a2, a1, a0) will cause the contents (d7, d6, d5, d4, d3, d2, d1, d0) of corresponding register (a5, 0, a3, a2, a1, a0) to be output MSB first on pin SDO (on the falling edge of SCK). Note that pin SDO is shared with an output pin, OP[11], therefore OEB should always be held low when register read-back data is expected on this pin. The next word may be read in to SDI while the previous word is still being output on SDO.

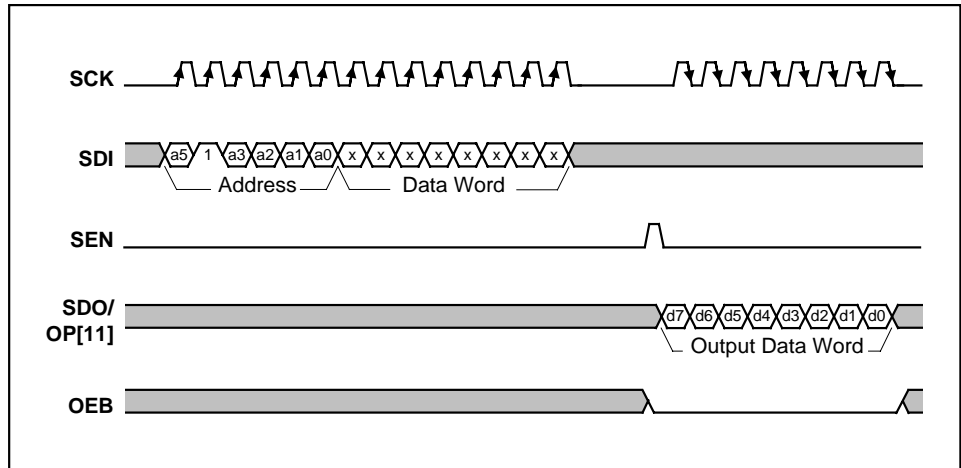

Figure 13 Serial Interface Register Read-back

**PARALLEL INTERFACE: REGISTER WRITE**

Figure 13 shows register write in parallel mode. The parallel interface uses bits OP[11:4] of the output bus and the STB, DNA and RNW pins. Pin RNW must be low during a write operation. The DNA pin defines whether the data byte is address (low) or data (high). The 6-bit address (a5, 0, a3, a2, a1, a0) is input into OP[9:4], LSB into OP[4], (OP[10] and OP[11] are ignored) when DNA is low, then the 8-bit data word is input into OP[11:4], LSB into OP[4], when DNA is high. The data bus OP[11:4] for both address and data is clocked in on the falling edge of STB. Note all valid registers have address bit a4 equal to 0.



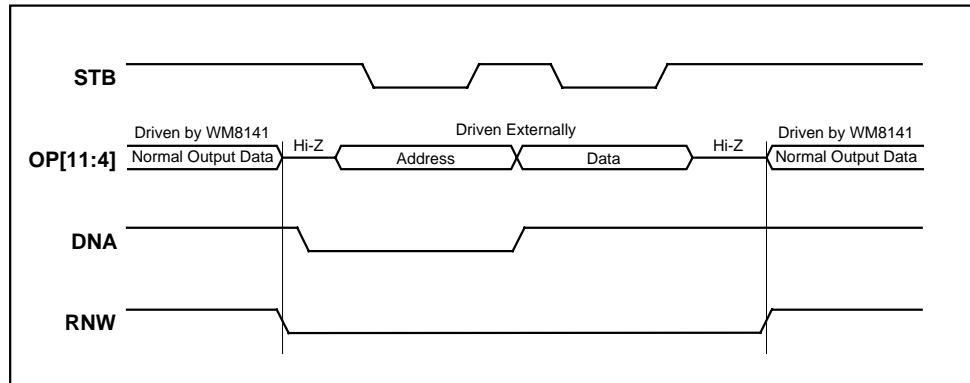

Figure 14 Parallel Interface Register Write

**PARALLEL INTERFACE: REGISTER READ-BACK**

Figure 15 shows register read-back in parallel mode. Read-back is initiated by writing the 6-bit address (a5, 1, a3, a2, a1, a0) into OP[9:4] by pulsing the STB pin low. Note that a4 = 1 and pins RNW and DNA are low. When RNW and DNA are high and STB is strobed again, the contents (d7, d6, d5, d4, d3, d2, d1, d0) of the corresponding register (a5, 0, a3, a2, a1, a0) will be output on OP[11:4], LSB on pin OP[4]. Until STB is pulsed low, the current contents of the ADC (shown as Normal Output Data) will be present on OP[11:4]. Note that the register data becomes available on the output data pins so OEB should be held low when read-back data is expected.

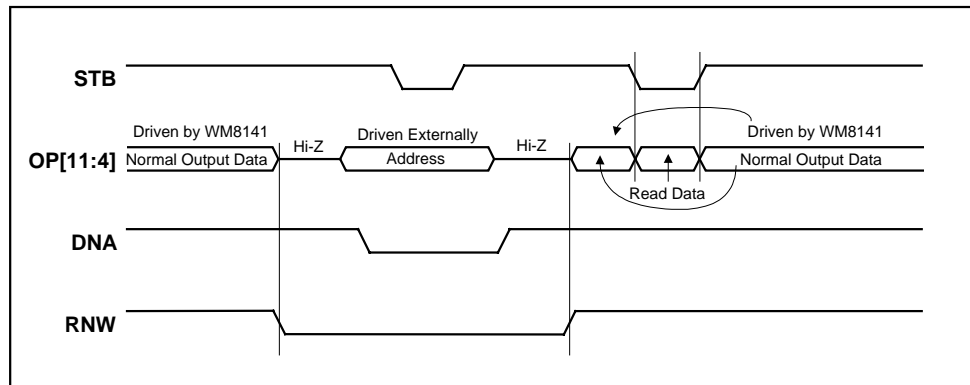

Figure 15 Parallel Interface Register Read-back

**TIMING REQUIREMENTS**

To use this device a master clock (MCLK) of up to 12MHz and a per-pixel synchronisation clock (VSMP) of up to 6MHz are required. These clocks drive a timing control block, which produces internal signals to control the sampling of the video signal. MCLK to VSMP ratios and maximum sample rates for the various modes are shown in Table 5.

**PROGRAMMABLE VSMP DETECT CIRCUIT**

The VSMP input is used to determine the sampling point and frequency of the WM8141. Under normal operation a pulse of 1 MCLK period should be applied to VSMP at the desired sampling frequency (as shown in the mode timing diagrams) and the input sample will be taken on the first rising MCLK edge after VSMP has gone low. However, in certain applications such a signal may not be readily available. The programmable VSMP detect circuit in the WM8141 allows the sampling point to be derived from any signal of the correct frequency, such as a CCD shift register clock, when applied to the VSMP pin.

When enabled, by setting the VSMPDET control bit, the circuit detects either a rising or falling edge (determined by POSNNEG control bit) on the VSMP input pin and generates an internal VSMP pulse. This pulse can optionally be delayed by a number of MCLK periods, specified by the VDEL[2:0] bits. Figure 16 shows the internal VSMP pulses that can be generated by this circuit for a typical clock input signal. The internal VSMP pulse is then applied to the timing control block in place of the normal VSMP pulse provided from the input pin. The sampling point then occurs on the first rising MCLK edge after this internal VSMP pulse, as shown in the mode timing diagrams.

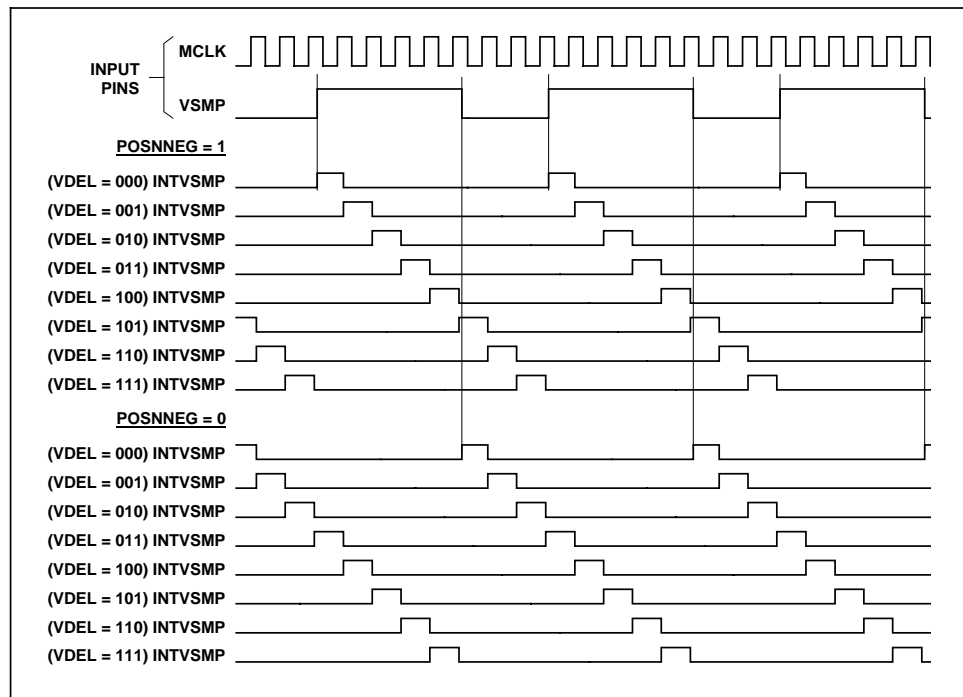

Figure 16 Internal VSMP Pulses Generated by Programmable VSMP Detect Circuit

REFERENCES

The ADC reference voltages are derived from an internal bandgap reference, and buffered to pins VRT and VRB, where they must be decoupled to ground. Pin VRX is driven by a similar buffer, and also requires decoupling. The output buffer from the RLCDAC also requires decoupling at pin VRLC/VBIAS

POWER SUPPLY

The WM8141 can run off either 3.3V or 5V single supplies or from split 5V (core) and 3.3V (digital interface) supplies.

POWER MANAGEMENT

Power management for the device is performed via the Control Interface. The device can be powered on or off completely by the EN bit. Alternatively, when control bit SELPD is high, only blocks selected by further control bits (SELDIS[3:0]) are powered down. This allows the user to optimise power dissipation in certain modes, or to define an intermediate standby mode to allow a quicker recovery into a fully active state. In Line-by-line operation, the green and blue channel PGAs are automatically powered down.

All the internal registers maintain their previously programmed value in power down modes and the Control Interface inputs remain active. Table 3 summarises the power down control bit functions.

EN	SELPD	
0	0	Device completely powers down.
1	0	Device completely powers up.
X	1	Blocks with respective SELDIS[3:0] bit high are disabled.

Table 3 Power Down Control

### LINE-BY-LINE OPERATION

Certain linear sensors (e.g Contact Image Sensors) give colour output on a line-by-line basis. i.e a full line of red pixels followed by a line of green pixels followed by a line of blue pixels. In order to accommodate this type of signal the WM8141 can be set into Monochrome mode, with the input channel switched by writing to control bits CHAN[1:0] between every line. Alternatively, the WM8141 can be placed into colour line-by-line mode by setting the LINEBYLINE control bit. When this bit is set the green and blue processing channels are powered down and the device is forced internally to only operate in MONO mode (because only one colour is sampled at a time) through the red channel. Figure 17 shows the signal path when operating in colour line-by-line mode.

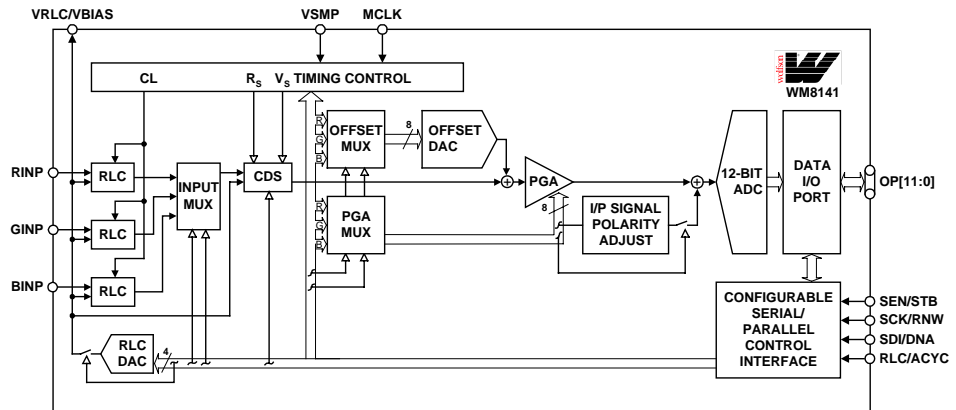

Figure 17 Signal Path When in Line-by-Line Mode

In this mode the input multiplexer and (optionally) the PGA/Offset register multiplexers can be auto-cycled by the application of pulses to the RLC/ACYC input pin by setting the ACYCNRLC register bit. The multiplexers change on the first MCLK rising edge after RLC/ACYC is taken high. Alternatively, all three multiplexers can be controlled via the serial interface by writing to register bits INTM[1:0] to select the desired colour. It is also possible for the input multiplexer to be controlled separately from the PGA and Offset multiplexers. Table 4 describes all the multiplexer selection modes that are possible.

FME	ACYCNRLC	NAME	DESCRIPTION
0	0	Internal, no force mux	Input mux, offset and gain registers determined by internal register bits INTM1, INTM0.
0	1	Auto-cycling, no force mux	Input mux, offset and gain registers auto-cycled, RINP → GINP → BINP → RINP... on RLC/ACYC pulse.
1	0	Internal, force mux	Input mux selected from internal register bits FM1, FM0; Offset and gain registers selected from internal register bits INTM1, INTM0.
1	1	Auto-cycling, force mux	Input mux selected from internal register bits FM1, FM0; Offset and gain registers auto-cycled, RINP → GINP → BINP → RINP... on RLC/ACYC pulse.

Table 4 Colour Selection Description in Line-by-Line Mode

## OPERATING MODES

Table 5 summarises the most commonly used modes, the clock waveforms required and the register contents required for CDS and non-CDS operation.

MODE	DESCRIPTION	CDS AVAILABLE	MAX SAMPLE RATE	SENSOR INTERFACE DESCRIPTION	TIMING REQUIREMENTS	REGISTER CONTENTS WITH CDS	REGISTER CONTENTS WITHOUT CDS
1	Colour Pixel-by-Pixel	Yes	2MSPS	The 3 input channels are sampled in parallel. The signal is then gain and offset adjusted before being multiplexed into a single data stream and converted by the ADC, giving an output data rate of 6MSPS max.	MCLK max MCLK: VSMP ratio is 6:1	SetReg1: 03(hex)	SetReg1: 01(hex)
2	Monochrome/ Colour Line-by-Line	Yes	2MSPS	As mode 1 except: Only one input channel at a time is continuously sampled.	MCLK max MCLK: VSMP ratio is 6:1	SetReg1: 07(hex)	SetReg1: 05(hex)
3	Fast Monochrome/ Colour Line-by-Line	Yes	4MSPS	Identical to mode 2	MCLK max MCLK: VSMP ratio is 3:1	Identical to mode 2 plus SetReg3: bits 5:4 must be set to 0(hex)	Identical to mode 2
4	Maximum speed Monochrome/ Colour Line-by-Line	No	6MSPS	Identical to mode 2	MCLK max MCLK: VSMP ratio is 2:1	CDS not possible	SetReg1: 45(hex)
5	Slow Colour	Yes	1.5MSPS	Identical to mode 1	MCLK max MCLK: VSMP ratio is 2n:1, n ≥ 4	Identical to mode 1	Identical to mode 1
6	Slow Monochrome/ Colour Line-by-Line	Yes	1.5MSPS	Identical to mode 2	MCLK max MCLK: VSMP ratio is 2n:1, n ≥ 4	Identical to mode 2	Identical to mode 2

**Table 5 WM8141 Operating Modes**

- Notes:**
1. In Monochrome mode, SetReg3 bits 7:6 determine which input is to be sampled.
  2. For Colour Line-by-Line, set control bit LINEBYLINE. For input selection, refer to Table 4, Colour Selection Description in Line-by-Line Mode.
  3. MCLK max = 12MHz at AVDD = 5V, MCLK max = 8MHz at AVDD = 3.3V.



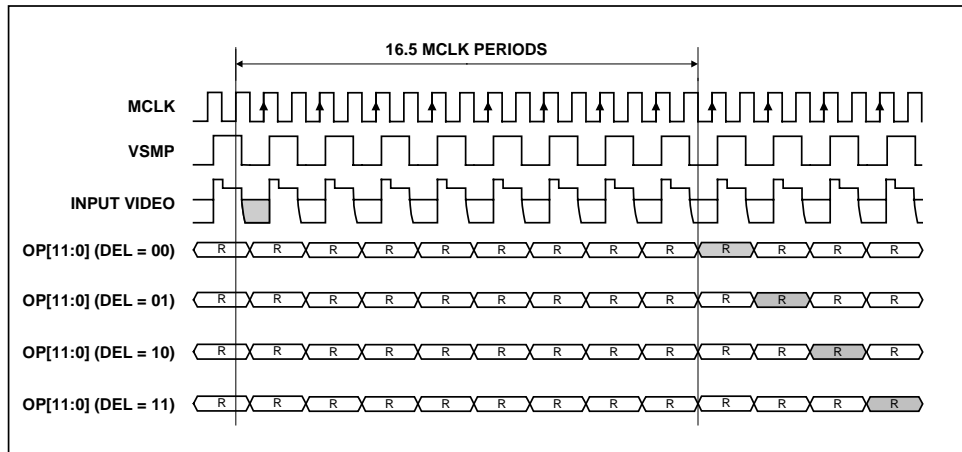

Figure 21 Mode 4 Operation

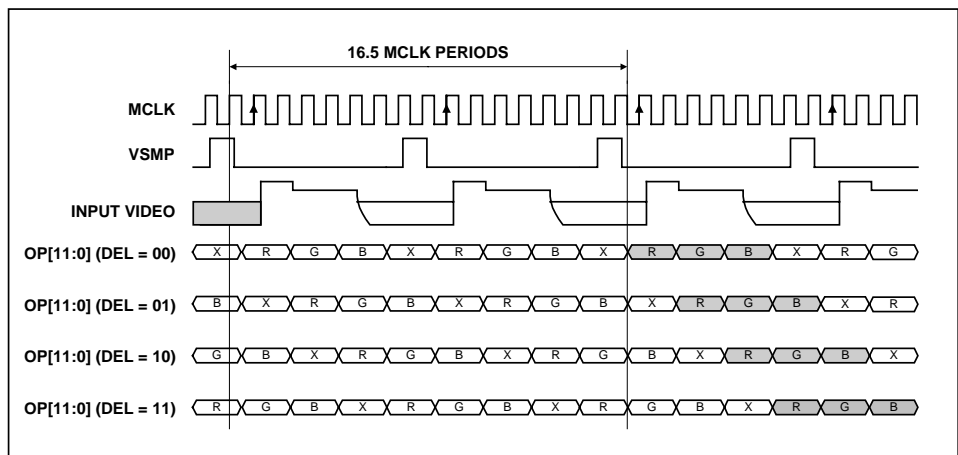

Figure 22 Mode 5 Operation (MCLK:VSMP Ratio = 8:1)

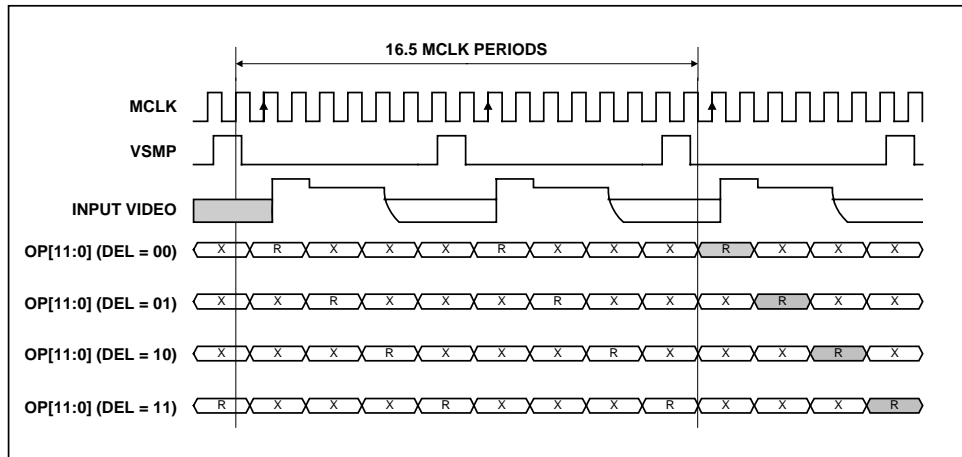

Figure 23 Mode 6 Operation (MCLK:VSMP Ratio = 8:1)

## DEVICE CONFIGURATION

### REGISTER MAP

The following table describes the location of each control bit used to determine the operation of the WM8141. The register map is programmed by writing (in serial or parallel) the required codes to the appropriate addresses.

ADDRESS <a5:a0>	DESCRIPTION	DEF (hex)	RW	BIT							
				b7	b6	b5	b4	b3	b2	b1	b0
000001	Setup Reg 1	03	RW		MODE4	PGAFS[1]	PGAFS[0]	SELPD	MONO	CDS	EN
000010	Setup Reg 2	20	RW	DEL[1]	DEL[0]	RLCDACRNG	0	VRLCEXT	INVOP	MUXOP[1]	MUXOP[0]
000011	Setup Reg 3	1F	RW	CHAN[1]	CHAN[0]	CDSREF [1]	CDSREF [0]	RLCV[3]	RLCV[2]	RLCV[1]	RLCV[0]
000100	Software Reset	00	W								
000101	Auto-cycle Reset	00	W								
000110	Setup Reg 4	00	RW	FM[1]	FM[0]	INTM[1]	INTM[0]	RLCINT	FME	ACYCNRLC	LINEBYLINE
000111	Revision Number	41	R								
001000	Setup Reg 5	00	RW	0	0	0	POSNNEG	VDEL[2]	VDEL[1]	VDEL[0]	VSMPDET
001001	Setup Reg 6	00	RW	0	0	0	0	SELDIS[3]	SELDIS [2]	SELDIS[1]	SELDIS[0]
001010	Reserved	00	RW	0	0	0	0	0	0	0	0
001011	Reserved	00	RW	0	0	0	0	0	0	0	0
001100	Reserved	00	RW	0	0	0	0	0	0	0	0
100000	DAC Value (Red)	80	RW	DAC[7]	DAC[6]	DAC[5]	DAC[4]	DAC[3]	DAC[2]	DAC[1]	DAC[0]
100001	DAC Value (Green)	80	RW	DAC[7]	DAC[6]	DAC[5]	DAC[4]	DAC[3]	DAC[2]	DAC[1]	DAC[0]
100010	DAC Value (Blue)	80	RW	DAC[7]	DAC[6]	DAC[5]	DAC[4]	DAC[3]	DAC[2]	DAC[1]	DAC[0]
100011	DAC Value (RGB)	80	W	DAC[7]	DAC[6]	DAC[5]	DAC[4]	DAC[3]	DAC[2]	DAC[1]	DAC[0]
101000	PGA Gain (Red)	00	RW	PGA[7]	PGA[6]	PGA[5]	PGA[4]	PGA[3]	PGA[2]	PGA[1]	PGA[0]
101001	PGA Gain (Green)	00	RW	PGA[7]	PGA[6]	PGA[5]	PGA[4]	PGA[3]	PGA[2]	PGA[1]	PGA[0]
101010	PGA Gain (Blue)	00	RW	PGA[7]	PGA[6]	PGA[5]	PGA[4]	PGA[3]	PGA[2]	PGA[1]	PGA[0]
101011	PGA Gain (RGB)	00	W	PGA[7]	PGA[6]	PGA[5]	PGA[4]	PGA[3]	PGA[2]	PGA[1]	PGA[0]

Table 6 Register Map

### REGISTER MAP DESCRIPTION

The following table describes the function of each of the control bits shown in Table 6.

REGISTER	BIT NO	BIT NAME(S)	DEFAULT	DESCRIPTION
Setup Register 1	0	EN	1	Global power down: 0 = complete power down, 1 = fully active.
	1	CDS	1	Select correlated double sampling mode: 0 = single ended mode, 1 = CDS mode.
	2	MONO	0	Mono/colour select: 0 = colour, 1 = monochrome operation.
	3	SELPD	0	Selective power down: 0 = no individual control, 1 = individual blocks can be disabled (controlled by SELDIS[3:0]).
	5:4	PGAFS[1:0]	00	Offsets PGA output to optimise the ADC range for different polarity sensor output signals. Zero differential PGA input signal gives: 00 = Zero output (use for bipolar video) 01 = Zero output 10 = Full-scale positive output (use for negative going video) 11 = Full-scale negative output (use for positive going video)
	6	MODE4	0	Required when operating in MODE4: 0 = other modes, 1 = MODE4.

REGISTER	BIT NO	BIT NAME(S)	DEFAULT	DESCRIPTION
Setup Register 2	1:0	MUXOP[1:0]	0	Determines the output data format. 00 = 12-bit output                      10 = 6-bit multiplexed mode (6+6 bits) 01 = 8-bit multiplexed (8+4 bits)    11 = 4-bit multiplexed mode (4+4+4 bits)
	2	INVOP	0	Digitally inverts the polarity of output data. 0 = negative going video gives negative going output. 1 = negative-going video gives positive going output data.
	3	VRLCEXT	0	When set powers down the RLCDAC, changing its output to Hi-Z, allowing VRLC to be externally driven.
	5	RLCDACRNG	1	Sets the output range of the RLCDAC. 0 = RLCDAC ranges from 0 to AVDD (approximately). 1 = RLCDAC ranges from 0 to VRT (approximately).
	7:6	DEL[1:0]	00	Sets the output latency in ADC clock periods. 1 ADC clock period = 2 MCLK periods except in mode 3 where 1 ADC clock period = 3 MCLK periods. 00 = Minimum latency                      10 = Delay by two ADC clock periods 01 = Delay by one ADC                      11 = Delay by three ADC clock periods clock period
Setup Register 3	3:0	RLCV[3:0]	1111	Controls RLCDAC driving VRLC pin to define single ended signal reference voltage or Reset Level Clamp voltage. See Electrical Characteristics section for ranges.
	5:4	CDSREF[1:0]	01	CDS mode reset timing adjust. 00 = Advance 1 MCLK period              10 = Retard 1 MCLK period 01 = Normal                                      11 = Retard 2 MCLK periods
	7:6	CHAN[1:0]	00	Monochrome mode channel select. 00 = Red channel select                      10 = Blue channel select 01 = Green channel select                      11 = Reserved
Software Reset			Any write to Software Reset causes all cells to be reset.	
Auto-cycle Reset			Any write to Auto-cycle Reset causes the auto-cycle counter to reset to RINP.	
Setup Register 4	0	LINEBYLINE	0	Selects line by line operation 0 = normal operation, 1 = line by line operation. When line by line operation is selected MONO is forced to 1 and CHAN[1:0] to 00 internally, ensuring that the correct internal timing signals are produced. Green and Blue PGAs are also disabled to save power.
	1	ACYCNRLC	0	When LINEBYLINE = 0 this bit has no effect. When LINEBYLINE = 1 this bit determines the function of the RLC/ACYC input pin and the input multiplexer and offset/gain register controls. 0 = RLC/ACYC pin enabled for Reset Level Clamp. Internal selection of input and gain/offset multiplexers. 1 = Auto-cycling enabled by pulsing the RLC/ACYC input pin. See Table 4, Colour Selection Description in Line-by-Line Mode for colour selection mode details. When auto-cycling is enabled, the RLC/ACYC pin cannot be used for reset level clamping. The RLCINT bit may be used instead.
	2	FME	0	When LINEBYLINE = 0 this bit has no effect. When LINEBYLINE = 1 this bit controls the input force mux mode: 0 = No force mux, 1 = Force mux mode. Forces the input mux to be selected by FM[1:0] separately from gain and offset multiplexers. See Table 4 for details.
	3	RLCINT	0	When LINEBYLINE = 1 and ACYCNRLC = 1 this bit is used to determine whether Reset Level Clamping is used. 0 = RLC disabled, 1 = RLC enabled.
	5:4	INTM[1:0]	00	Colour selection bits used in internal modes. See Table 4 for details. 00 = Red, 01 = Green, 10 = Blue and 11 = Reserved.
	7:6	FM[1:0]	00	Colour selection bits used in input force mux modes. See Table 4 for details. 00 = Red, 01 = Green, 10 = Blue and 11 = Reserved.



REGISTER	BIT NO	BIT NAME(S)	DEFAULT	DESCRIPTION
Setup Register 5	0	VSMPDET	0	0 = Normal operation, signal on VSMP input pin is applied directly to Timing Control block. 1 = Programmable VSMP detect circuit is enabled. An internal synchronisation pulse is generated from signal applied to VSMP input pin and is applied to Timing Control block.
	3:1	VDEL[2:0]	000	When VSMPDET = 0 these bits have no effect. When VSMPDET = 1 these bits set a programmable delay from the detected edge of the signal applied to the VSMP pin. The internally generated pulse is delayed by VDEL MCLK periods from the detected edge. See Figure 16 Internal VSMP Pulses Generated by Programmable VSMP Detect Circuit, for details.
	4	POSNEG	0	When VSMPDET = 0 this bit has no effect. When VSMPDET = 1 this bit controls whether positive or negative edges are detected: 0 = Negative edge on VSMP pin is detected and used to generate internal timing pulse. 1 = Positive edge on VSMP pin is detected and used to generate internal timing pulse. See Figure 15 for further details.
Setup Register 6	3:0	SELDIS[3:0]	0	Selective power disable register - activated when SELPD = 1. Each bit disables respective function when 1, enabled when 0. SELDIS[0] = Red CDS, PGA SELDIS[1] = Green CDS, PGA SELDIS[2] = Blue CDS, PGA SELDIS[3] = ADC

Table 7 Register Control Bits

## APPLICATIONS RECOMMENDATIONS

### INTRODUCTION

The WM8141 is a mixed signal device, therefore careful PCB layout is required. The following section contains PCB layout guidelines, which are recommended for optimal performance from the WM8141, and some typical applications circuits.

### PCB LAYOUT

- 1) Use separate analogue and digital power and ground planes. The analogue and digital ground planes should be connected as close as possible to, or underneath, the WM8141.
- 2) Place all supply decoupling capacitors as close as possible to their respective supply pins and provide a low impedance path from the capacitors to the appropriate ground.
- 3) Avoid noise on AGND, pin 13.
- 4) Avoid noise on reference pins VRT, VRB and VRX. Place the decoupling capacitors as close as possible to these pins and provide a low impedance path from the capacitors to analogue ground.
- 5) Input signals should be screened from each other and from other sources of noise to avoid cross-talk and interference.
- 6) Minimise load capacitance on digital outputs. Capacitive loads of greater than 20pF will degrade performance. Use buffers if necessary and keep tracks short.

### TYPICAL APPLICATIONS DIAGRAMS

The WM8141 is intended to be used in three types of architecture.

- Monochrome
- Colour Pixel-By-Pixel
- Colour Line-By-Line

Each of these architectures is outlined in this section.

The output from a CCD sensor usually has a high impedance and must therefore be buffered as close to the sensor as possible. The sensor manufacturers' datasheets specify the buffer circuit to use.

Initially, the designer must decide if CDS and RLC are to be used. The WM8141 supports both of these functions and Wolfson recommend using both CDS and pixel-by-pixel RLC for optimal performance. In this case a low value a.c. coupling capacitor is required between the sensor and the WM8141. Experiments have shown that a 100pF capacitor is the optimum value to use, however this may vary for particular applications depending on speed of operation and PCB layout.

**MONOCHROME CCD**

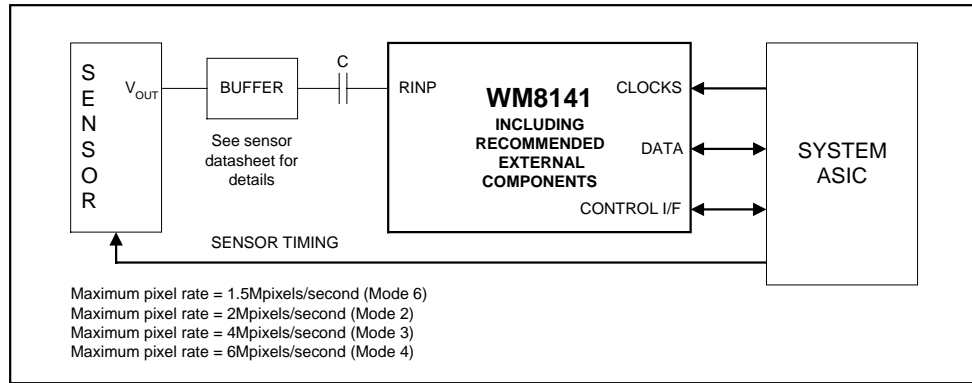

**Figure 24 Block Diagram of Monochrome CCD Application, AC Coupled**

REGISTER		SETTING		NOTE
NAME	ADDRESS	HEX	BINARY	
Set-up register 1	000001	2F	0010 1111	EN = 1: Device enabled; CDS = 1: CDS enabled; MONO = 1: Monochrome operation; SELPD = 1: Selective power down possible; PGAFS[1:0] = 10: ADC range optimised for negative going video; MODE4 = 0: Only set when 2:1 MCLK:VSMP ratio required (mode 4).
Set-up register 2	000010	20	0010 0000	MUXOP[1:0] = 00: 12-bit parallel output; INVOP = 0: Output data not inverted; VRLCEXT = 0: RLCDAC required to provide reset level clamp voltage since sensor is AC coupled; RLCDACRNG = 1: RLCDAC range is 0V to V <sub>RT</sub> ; DEL[1:0] = 00: Default latency.
Set-up register 3	000011	1F	0001 1111	RLCV[3:0] = 1111: RLCDAC full scale voltage; CDSREF[1:0] = 01: Default reset sample position; CHAN[1:0] = 00: Red channel selected.
Set-up register 4	000101	00	0000 0000	Line-by-line mode not used so this register is not required.
Set-up register 5	001000	00	0000 0000	Only used if programmable VSMP circuit is required.
Set-up register 6	001001	06	0000 0110	SELDIS[3:0] = 0110: Disable green and blue channels to reduce power.

**Table 8 Typical Control Register Settings for Figure 24 (CDS, Negative-Going CCD Video Signal, MCLK:VSMP = 2:1/3:1/6:1/8:1)**

COLOUR PIXEL-BY-PIXEL

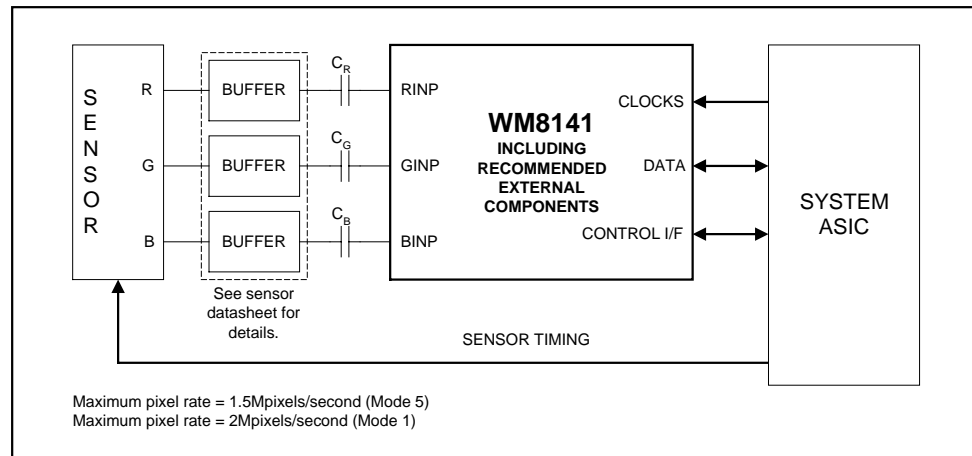

Figure 25 Block Diagram of Colour Pixel-By-Pixel Application, AC Coupled

REGISTER		SETTING		NOTE
NAME	ADDRESS	HEX	BINARY	
Set-up register 1	000001	13	0010 0011	EN = 1: Device enabled; CDS = 1: CDS enabled; MONO = 0: Colour operation; SELPD = 0: No selective power down; PGAFS[1:0] = 10: ADC range optimised for negative going video; MODE4 = 0: Not required for colour.
Set-up register 2	000010	20	0010 0000	MUXOP[1:0] = 00: 12-bit parallel output; INVOP = 0: Output data not inverted; VRLCEXT = 0: RLCDAC required to provide reset level clamp voltage since sensor is AC coupled; RLCDACRNG = 1: RLCDAC range is 0V to V <sub>RT</sub> ; DEL[1:0] = 00: Default latency
Set-up register 3	000011	1F	XX01 1111	RLCV[3:0] = 1111: RLCDAC full scale voltage; CDSREF[1:0] = 01: Default reset sample position; CHAN[1:0] = XX: Colour mode so not required.
Set-up register 4	000101	00	0000 0000	Line-by-Line mode not used so this register is not required.
Set-up register 5	001000	00	0000 0000	Only used if programmable VSMP circuit is required.
Set-up register 6	001001	00	0000 0000	All channels enabled.

Table 9 Typical Control Register Settings for Figure 25 (CDS, Negative-Going CCD Video Signal, MCLK:VSMP = 6:1/8:1)

COLOUR LINE-BY-LINE

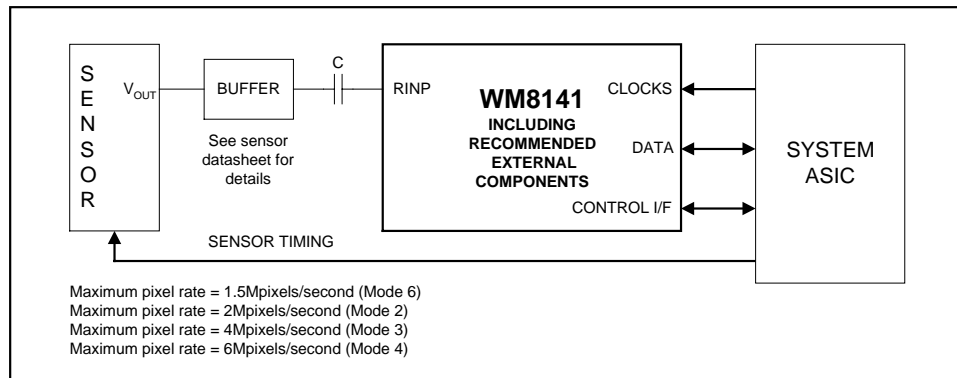

Figure 26 Block Diagram Of Colour Line-By-Line Application, AC Coupled

REGISTER		SETTING		NOTE
NAME	ADDRESS	HEX	BINARY	
Set-up register 1	000001	23	0010 0X11	EN = 1: Device enabled; CDS = 1: CDS enabled; MONO = X: Forced internally when LINEBYLINE is set; SELPD = 0: No selective power down; PGAFS[1:0] = 10: ADC range optimised for negative going video; MODE4 = 0: set high if MCLK:VSMP ratio of 2:1 is required.
Set-up register 2	000010	20	0010 0000	MUXOP[1:0] = 00: 12-bit parallel output; INVOP = 0: Output data not inverted; VRLCEXT = 0: RLCDAC required to provide reset level clamp voltage since sensor is AC coupled; RLCDACRNG = 1: RLCDAC range is 0V to V <sub>RT</sub> ; DEL[1:0] = 00: Default latency.
Set-up register 3	000011	1F	01 1111	RLCV[3:0] = 1111: RLCDAC full scale voltage; CDSREF[1:0] = 01: Default reset sample position; CHAN[1:0] = XX: Colour mode so not required.
Set-up register 4	000101	0B	00XX 1111	LINEBYLINE = 1: Line by line mode selected; ACYCNRLC = 1: Auto-cycling required; FME = 1: Input mux controlled by FME bits; RLCINT = 1: RLC performed on every pixel; INTM[1:0] = XX: PGA/Offset multiplexers controlled by auto-cycling so these bits have no effect; FME[1:0] = 00: Controls input multiplexer to select red channel.
Set-up register 5	001000	00	0000 0000	Only used if programmable VSMP circuit is required.
Set-up register 6	001001	00	0000 0000	Green and blue channels are automatically powered down when LINEBYLINE = 1.

Table 10 Typical Control Register Settings for Figure 26 (CDS, Negative-Going CCD Video Signal, MCLK/VSMP = 2:1/3:1/6:1/8:1)

RECOMMENDED EXTERNAL COMPONENTS

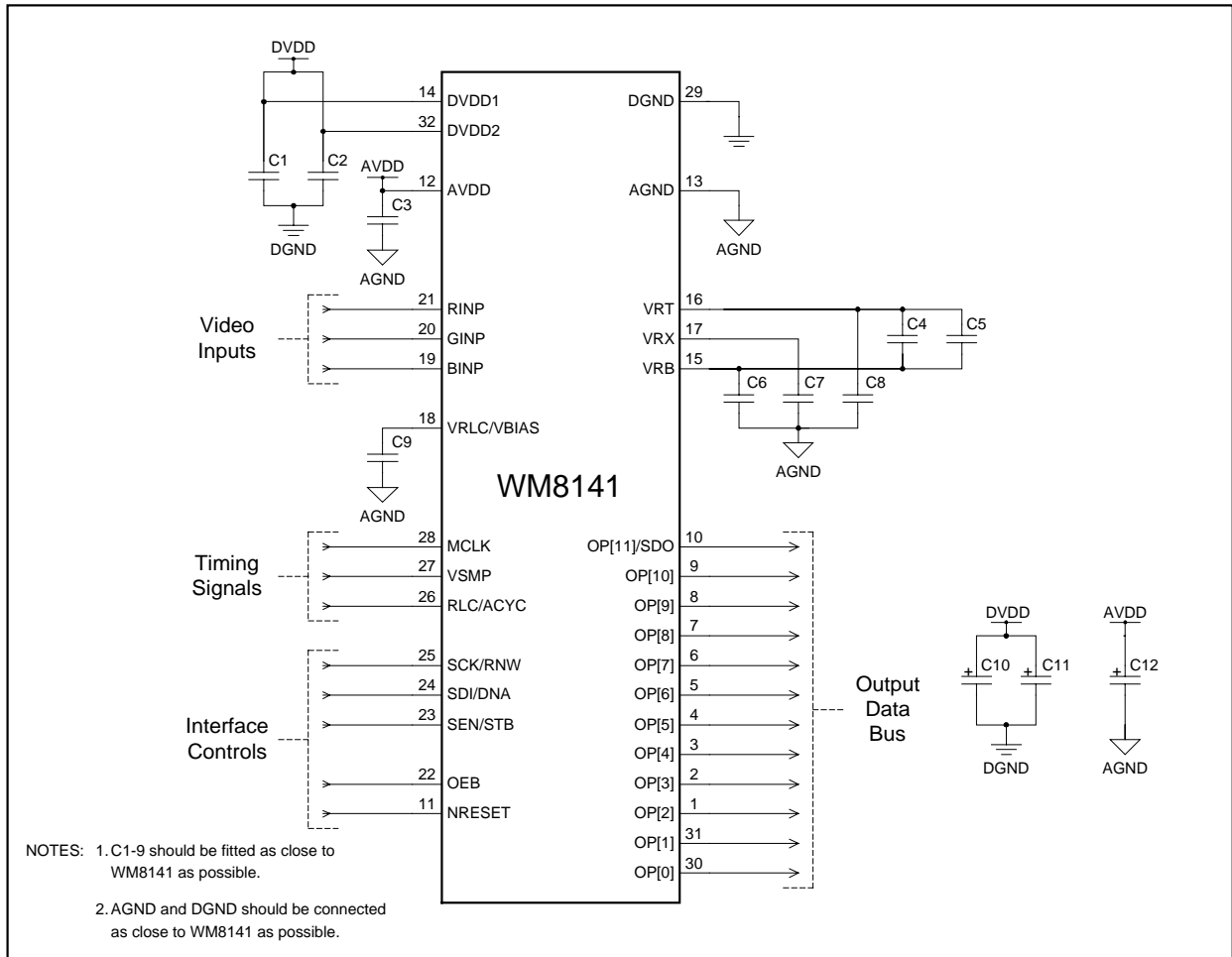
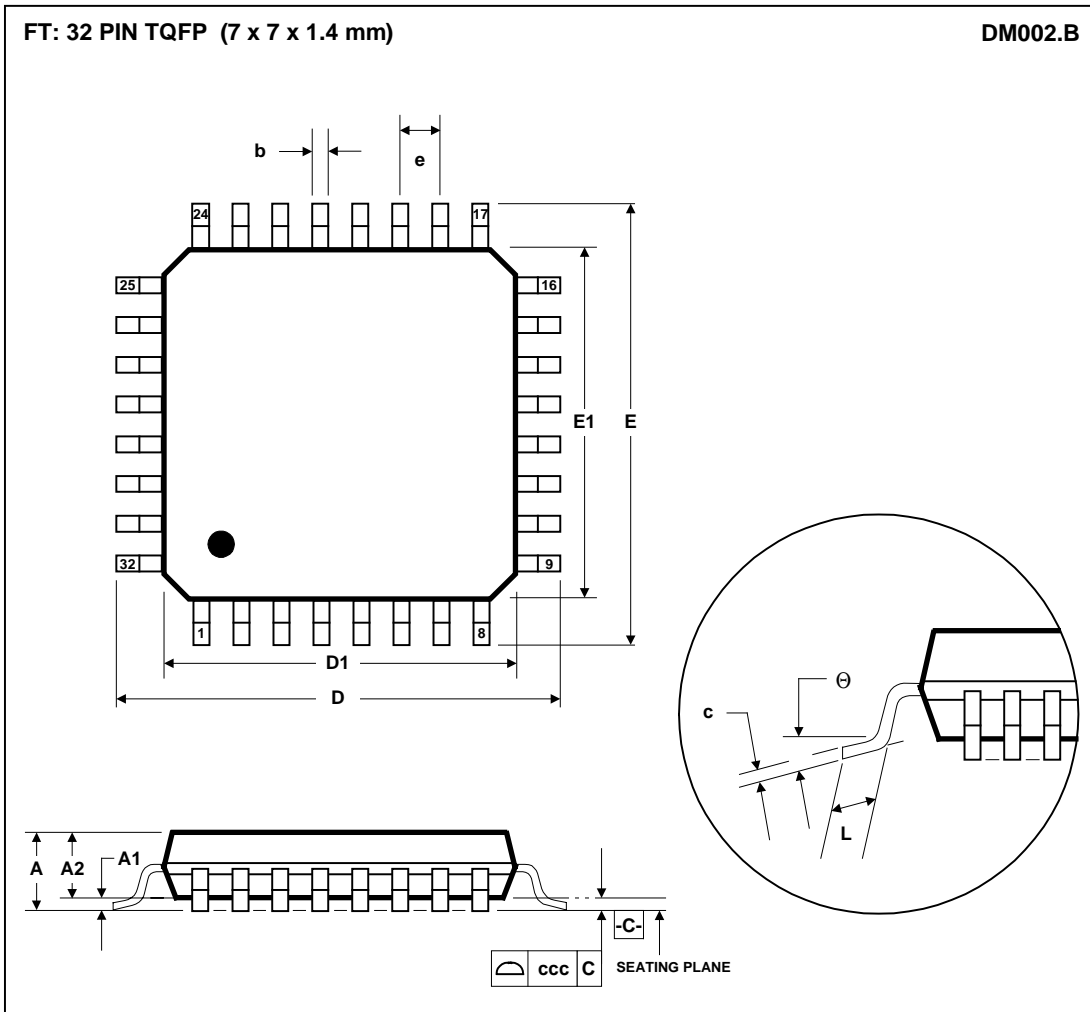

Figure 27 External Components Diagram

COMPONENT REFERENCE	SUGGESTED VALUE	DESCRIPTION
C1	100nF	De-coupling for DVDD1.
C2	100nF	De-coupling for DVDD2.
C3	100nF	De-coupling for AVDD.
C4	10nF	High frequency de-coupling between VRT and VRB.
C5	1µF	Low frequency de-coupling between VRT and VRB (non-polarised).
C6	100nF	De-coupling for VRB.
C7	100nF	De-coupling for VRX.
C8	100nF	De-coupling for VRT.
C9	100nF	De-coupling for VRLC.
C10	10µF	Reservoir capacitor for DVDD.
C11	10µF	Reservoir capacitor for DVDD.
C12	10µF	Reservoir capacitor for AVDD.

Table 11 External Components Descriptions

**PACKAGE DIMENSIONS**



Symbols	Dimensions (mm)		
	MIN	NOM	MAX
A	-----	-----	1.60
A <sub>1</sub>	0.05	-----	0.15
A <sub>2</sub>	1.35	1.40	1.45
b	0.30	0.37	0.45
c	0.09	-----	0.20
D	9.00 BSC		
D <sub>1</sub>	7.00 BSC		
E	9.00 BSC		
E <sub>1</sub>	7.00 BSC		
e	0.80 BSC		
L	0.45	0.60	0.75
θ	0°	3.5°	7°
Tolerances of Form and Position			
ccc	0.10		
REF:	JEDEC.95, MS-026		

- NOTES:  
 A. ALL LINEAR DIMENSIONS ARE IN MILLIMETERS.  
 B. THIS DRAWING IS SUBJECT TO CHANGE WITHOUT NOTICE.  
 C. BODY DIMENSIONS DO NOT INCLUDE MOLD FLASH OR PROTRUSION, NOT TO EXCEED 0.25MM.  
 D. MEETS JEDEC.95 MS-026, VARIATION = BBA. REFER TO THIS SPECIFICATION FOR FURTHER DETAILS.